

# ESTETIKA<sup>®</sup>

BY



CLEARLINE  
WINDOWS Ltd



Anti-Mosquito Screens

## GOODBYE TO MOSQUITO'S & INSECTS FOREVER!

New tested Antimole  
technology

Automatic adjustment of  
out-of-square

New full-frame design

Safe, quick installation and  
also without screws

Adjustable retractable  
mesh screen

Retractable brush with  
total disappearance

New generation  
CLIC-CLAK® hook-  
release system

Telescopic and self-  
adjusting guides

## GOODBYE TO MOSQUITOS AND UNWANTED INSECTS!

Do mosquito's, flies and cockroaches invade your home? Clearline finally has the answer for you!

Estetika by Clearline, is an innovative flyscreen in every aspect: aesthetic concept, functionality and practical installation. Estetika® a true barrier against these very annoying insects. But that's not all. Installation is simple and fast and can even be performed without the use of screws. Additionally, newly designed profiles ensure a "full frame" finish of high aesthetic value, further enhanced by brushes and small covers that "disappear" inside the aluminum profiles. Self-adjusting telescopic guides and the famous Clic-clak® provides the perfect solution. Estetika®'s by Clearline offers a state-of-the-art mosquito net.

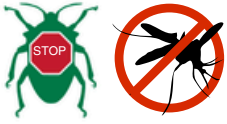

# MAIN FOCUS

Patented  
Technology

## ANTIMOLECULAR TECHNOLOGY

Profiles and plastics have been designed to offer an effective barrier against annoying mosquito's and insects that easily enter homes. Estetika® by Clearline has been designed to eliminate all possible entry routes. Keeping insects out.

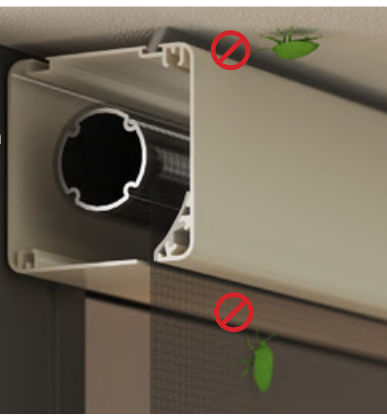

## DESIGN A FULL FRAME

Essential and clean lines combined with a guide as wide as the box to ensure a perfect "full frame" finish around the opening: the wide guide eliminates the unsightly gap that usually forms between the guide and the frame, a space that is difficult to clean.



## SELF-RECORDING TELESCOPIC GUIDES

Thanks to its telescopic profiles and the standard upper brush, Estetika® by Clearline also fits the most irregular compartments without the addition of spacers, silicone, or various seals. The guides adapt and self-adjust easily whenever the handlebar is lowered.



## INSTALLATION WITHOUT SCREWS

(between window frame and shutter/blind)

Installation in a hole even without screws thanks to the combination of the thrust group and double-sided tape provided. With this system it is possible to correct misalignments which can be up to 10 mm.



## BLACK VEIL NET

Evolution of the classic net, more resistant and high-performing. It protects against damage caused by sunlight thanks to a slight shading effect, which gives it a GTOT of 0.34 if placed outside a C glass, making your mosquito net a sun protection and therefore qualifying for tax deductions for building energy retrofitting.

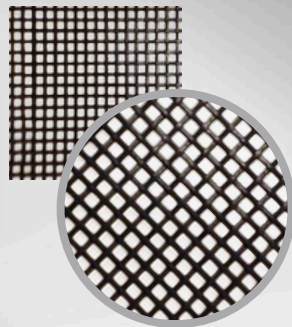

## SAFETY CLUTCH

(for spring version)

The safety clutch is a braking mechanism that gently accompanies the upward movement of the handlebar and, in case of accidental loss of grip, prevents causing even serious harm to people.

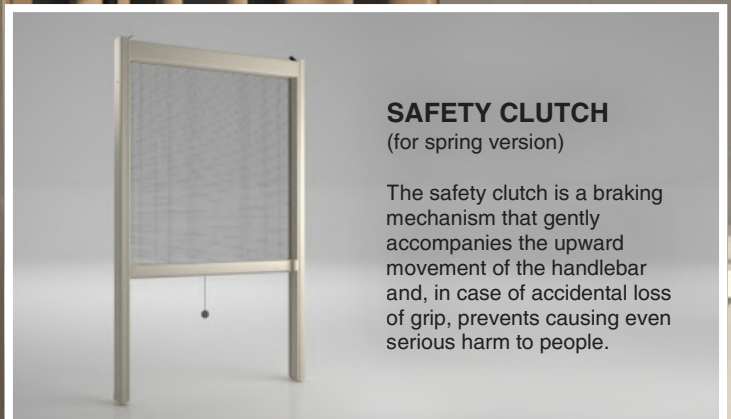

## WIND RESISTANCE

Class 6 with ANIMA21®, the patented windproof system designed to make mosquito nets super resistant. ANIMA21® intelligently combines aesthetics and functionality because it withstands pressure while allowing the automatic retraction of the net, ensuring its durability and operation.

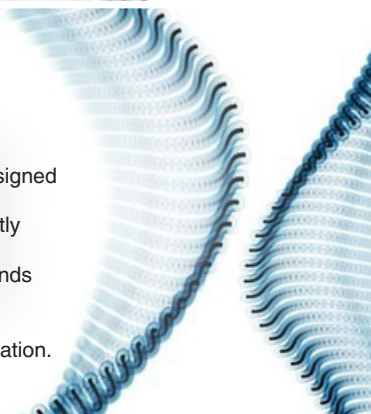

## RECHARGEABLE BATTERY MOTOR

(for motorized version)

The rechargeable battery allows Estetika® by Clearline Motorized to be installed even where no electrical system is planned. The lithium-ion battery ensures that the mosquito net can be operated for days before needing to be recharged, thanks to the dedicated magnetic charging connector accessible without having to remove the mosquito net.

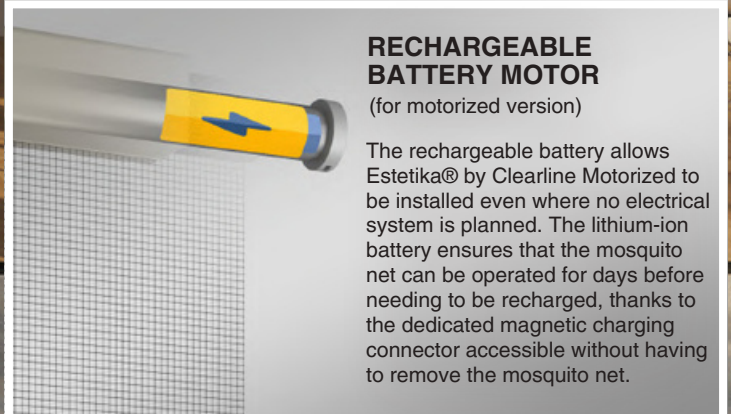

# ESTETIKA®

## NEW TECHNOLOGY

BY



# CLEARLINE

WINDOWS Ltd

with Anima21®

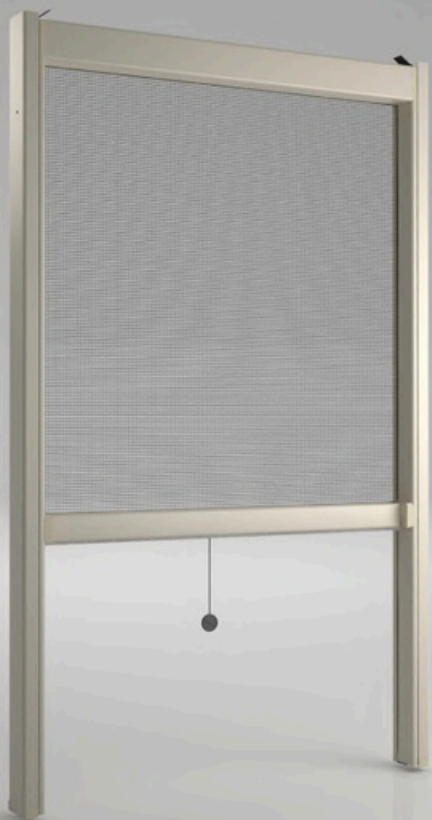

### MAXIMUM MEASURES

Loose version: 2000x2700mm and 2500x1800mm  
Motorized version: 2700x2700 mm

### TOTAL SIZE

50 mm

### REGULATIONS

Height adjustment: +10mm

Width compensation: -4/+10 mm without double-sided tape; +14 mm with double-sided tape

### TYPE OF NETWORK

Estetika® by Clearline and Estetika® by Clearline Motorized available with gray, black, and black Velum mesh, the mesh which offers protection against the sun's rays thanks to a light shading effect.

### DARKENING AND FILTERING

The blackout-filter version allows you to perfectly control and adjust the amount of light that penetrates inside the room.

### RECOMMENDED PAIRING

Neoscenica lateral sliding lantern without barriers for doors. Neoscenica® has an essential design, is effective against insects, and is resistant to wind and impacts thanks to ANIMA21®.

### EASY INSTALLATION

Optimizing installation times is a priority for us. The accessories that were provided in a bag are now pre-installed on the Estetika by Clearline case and track (in hole).

## TECHNICAL FEATURES

Bin and Handle Bar

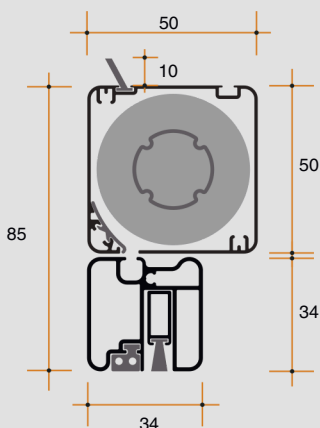

Estetika® by Clearline Telescopic Guide

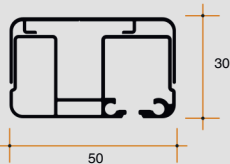

Estetika® by Clearline Motorized Telescopic Guide

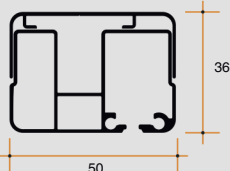

## ALUMINUM COLOURS

RAL 9010 matte-glossy*	RAL 1013 matte-glossy*	RAL 9001 matte-glossy*	SILVER oxidizes to brush	SILVER paint yourself*	RAL 7001 matt	RAL 7016 matt	Michelangelo GREY	RAL 9005 matt
BRONZE paint yourself*	MORO HEAD 2001 matte	RAL 8017 matte	BROWN Michelangelo	ELOX 2000 matt	RAL 6005 matt	GREEN Michelangelo		
IROKO	DOUGLAS	PINO	RENOLIT clear	CHERRY TREE	RENOLIT dark	OAK	NUT	ACACIA

Grey-coloured accessories. The Bronze, 9001, 9010, and 1013 colours include some matching accessories. The colour of the accessories in special colours is at the Company's discretion. \* Standard colouring unless otherwise specified on the order. Exposure of plastics to UV rays may alter their colour.



# CLEARLINE

WINDOWS Ltd

Clearline Windows Ltd  
Head Office Unit 14-15 Burke Road  
Totnes Ind Est, Totnes  
Devon, TQ9 5XL  
Tel: 01803 658444  
VAT 827050348  
sales@clearlinewindows.co.uk  
www.clearlinewindows.co.uk